

**SUNGAI  
DESIGN**



**Product Specs**



The Muara Bench extends the narrative of Sungai Design's Muara series, blending simplicity and sustainability into a modern statement piece. Made from 1,200 up-cycled plastic bags, its rounded top is supported by two sturdy legs joined by a sleek, central bar. Designed for the indoors, the Muara Bench offers a minimalist aesthetic that enhances any space while promoting eco-conscious living.

Durable and easy to assemble, the flat-pack design bench is available in two colors, Pebble White and Granite Black. The Muara Bench's flowing lines and organic curves provides both a sense of calm and unity, making it an ideal statement piece for any environment. For an elevated experience of comfort and style, an optional cushion can be added in black or white.

Choosing the Muara Bench is a commitment to both eco-consciousness and fine craftsmanship. It brings the harmony of natural forms and innovative design into your space, demonstrating that beauty often arises from the most unlikely origins.



# Muara Stool

## Information

### Design

Dimas Jadidan, 2024

### Environment

Indoor

### Materials

River plastic bags from Bali (LDPE)

### Weight

21 kilograms of up-cycled plastic

## Finishes

### Recycled LDPE

 Granite Black

 Pebble White

Each product features a unique finish, with subtle variations in color and texture.

### Impact

1,200 plastic bags up-cycled

## Dimensions

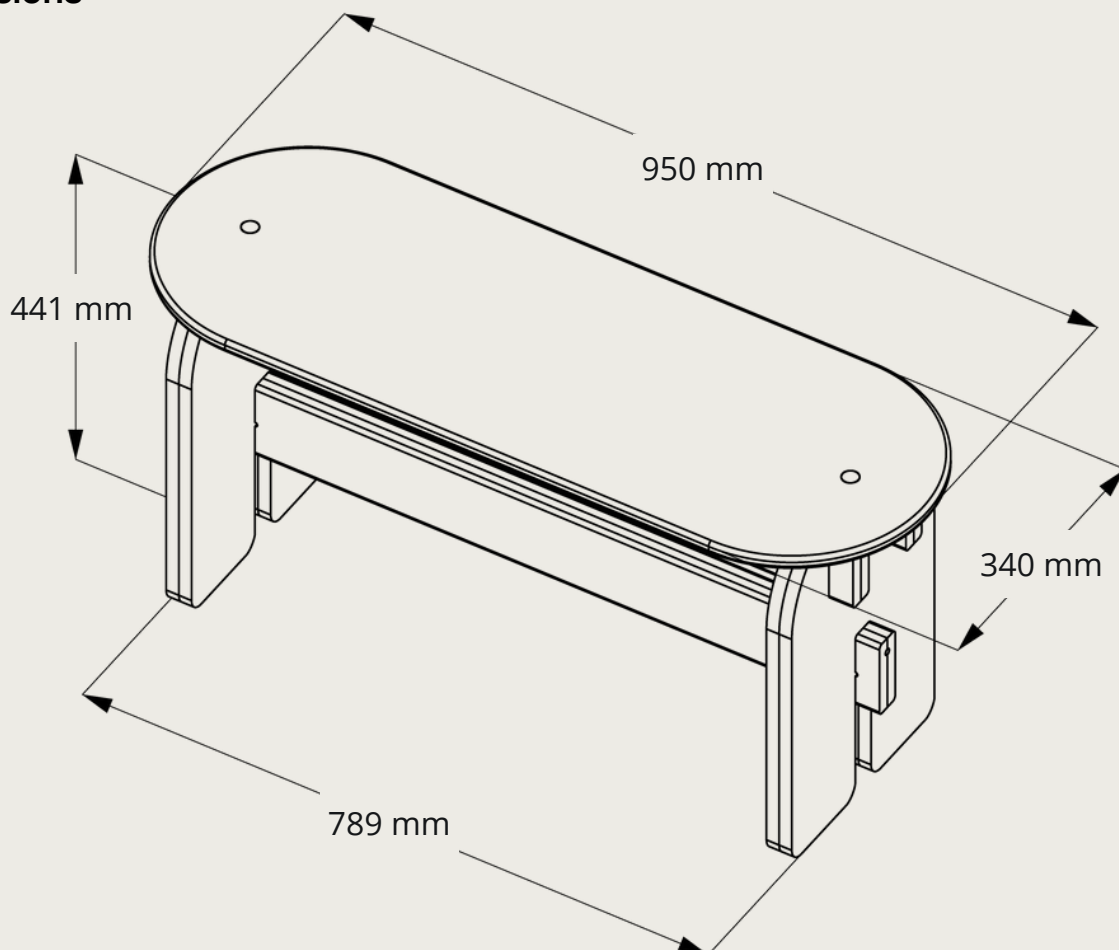





# SUNGAI DESIGN