

Wilkhahn

Confair folding table.
440 range.





Confair folding table.

Confair folding tables make versatile usage of cleverly designed conference and meeting areas child's play. Only one single person is required to set up and rearrange the movable folding tables – without any tools, releasing or unlocking procedures or special skills involved. Snap connectors allow the tables to be linked in any direction. If partitions are used to divide up rooms, conference or project work tables can be transformed into a large conference layout in no time. It's encouraging to reflect that an investment in Confair folding tables can pay dividends quickly...

The sophisticated technology and the large lockable casters, as well as the elegant design and high-quality materials, are equally responsible for the table's success. The table's structure makes it simple to use and transport. The look of the table reflects communication at a high level and ranges from the conference and project-work room, to top-level executive offices. As options, cable channels, power supply connections and innovative techni-modules ensure interactive access to state-of-the-art multi-media equipment is so easy it has to be believed. The table is the perfect mix of efficient use of space, aesthetic appeal and advanced technical functionality.

And if the Confair tables come with Power Bars, more complex seminar or conference settings in rows or blocks can even be connected to a power supply via one single socket. As a result, this cuts the number of connections in the wall or floor significantly. And it doesn't just reduce fitting costs and the number of floor ports, but also means that spaces that are protected for their cultural heritage value can be used in a very versatile way.

[📺 Confair video](#)

Models 440/00 with Modus cantilever chairs, model 279/7.
Design: Klaus Franck, Werner Sauer and Wiege, Fritz Frenkler, Justus Kolberg. Photo: Thomas Bach.

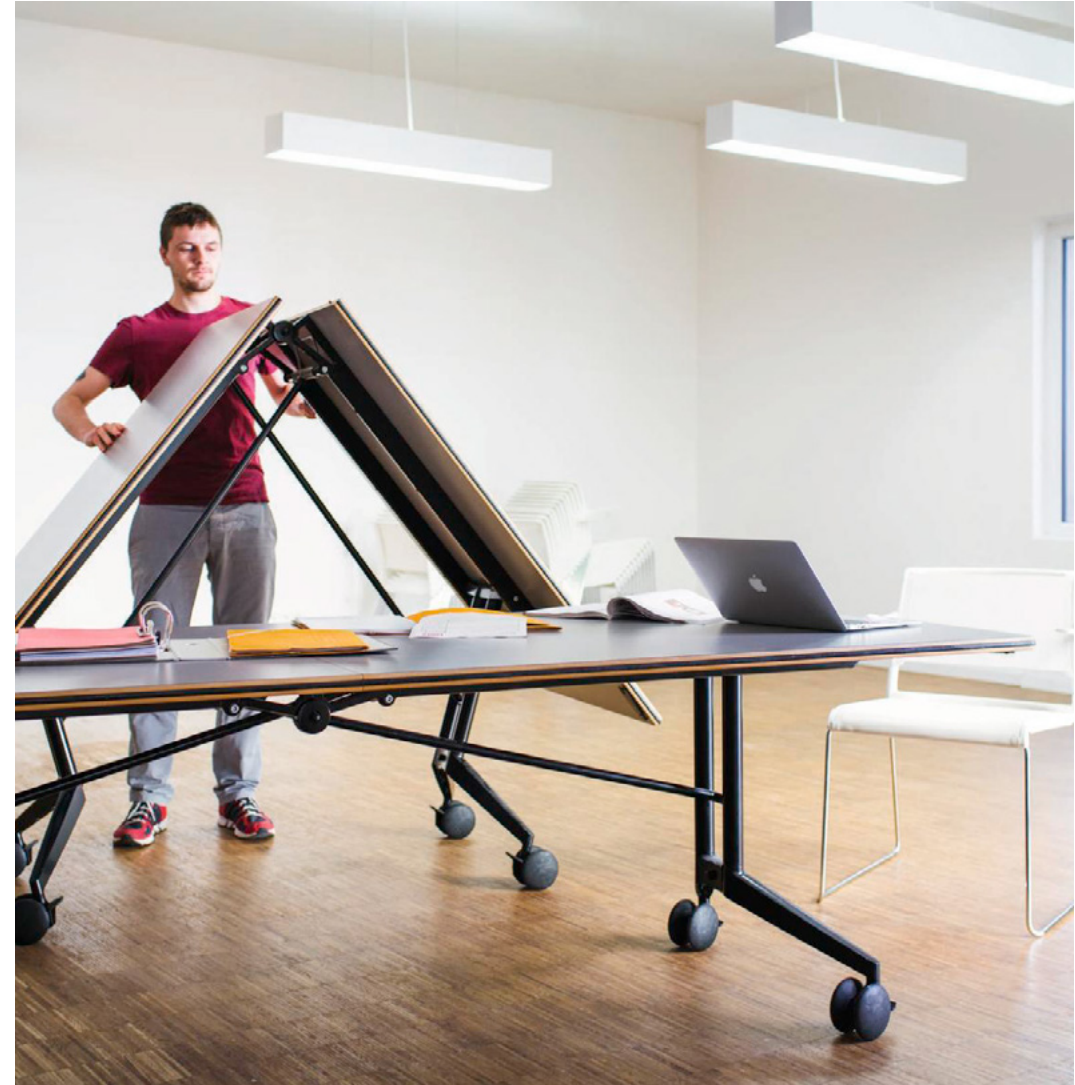

Model 440/00 with 230/2 Aline sled-base chair. Design: Andreas Störiko. Photos: Frank Schinski.



Model 440/00 with two Power Bars for superior connectivity. Image: Wilkhahn and 1zu33.



Model 440/00 with Occo chairs, model 222/40. Design Jehs & Laub, and Aula stacking chairs, model 238/10. Design: Wolfgang C.R. Mezger. Building: theCo, University of St. Gallen, Switzerland. Photo: Anna-Tina Eberhard.



Models 440/00 with Aula stacking chairs, model 238/10. Design: Wolfgang C.R. Mezger. Photos: Frank Schinski.



Model 440/00 with Graph conference chairs, model 301/6. Design: Jehs & Laub. Building: Rostelecom, Moscow, Russia. Photo: Solo Office Interiors.



Model 440/00 with Metrik cantilever chairs, model 186/3. Design: WhiteID. Confair flipchart, model 442/1 and Confair lectern, model 448/9. Design: wiege, Fritz Frenkler, Justus Kolberg. Building: Die Sandburg Hotel, Langeoog, Germany. Photo: Leuchtende Hotelfotografie, Thomas Haberland.



Model 440/00 with Timetable Lift, model 615/00. Design: Andreas Störiko and Metrik cantilever chairs, model 186/3. Design: WhiteID. Building: Zeitgeist Hotel, Vienna, Austria. Photo: Stefan Huger / studiohuger.at.

Confair folding table. 440 range. Product versions.

Wilkhahn



Frame: fully coated in silver, satin finish, table top natural oak



Frame: polished aluminum, clear anodized, natural beech table top

Table top groups



Laminate, laminate with wood decor, soft matte laminate, veneer variant 1 or 2, you can find all surfaces in our media center.

Laminate. The material is made by bonding cellulose and décor paper layers, as well as resin, by applying heat and pressure. This produces an extremely tough surface that comes in a variety of different colors. Laminate is highly recommended for areas where the tables are subject to a lot of wear and tear because they are frequently moved around for example.

Wood veneers. Natural wood is a living material: in the way it looks and changes over the years. Sometimes more significantly and sometimes more subtly, depending on the type of wood and how light it is. If a more consistent look is preferred, stained surfaces or industrially produced veneer are available.

Foot section and upright

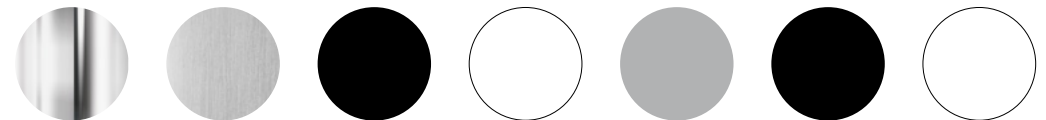

Bright chrome-plated or polished aluminum, coated in black, white or with a silver satin finish, with a black or white coating with textured matte finish

The digital sample colors differ from the originals. You can find our current fabric collection in our media center.

Confair folding table. 440 range. Table edges.

Wilkhahn

Edge profiles



Standard version: Wood edging bullnose (double) with an integrated impact-resilient profile, Alternatively: Straight wood edging with integrated impact-resilient profile or straight plastic edging (only in the case of laminate variant 1 and 2)

Bullnose edge with a black impact-resilient profile, table top 26 mm (1/8") thick

Bullnose edge with a white impact-resilient profile, table top 26 mm (1/8") thick

Coated bullnose edge with a black impact-resilient profile, table top 26 mm (1/8") thick

Straight edge with a black impact-resilient profile, table top 26 mm (1/8") thick

Straight edge with a white impact-resilient profile, table top 26 mm (1/8") thick

Straight plastic edging, Table top 26 mm (1/8") thick

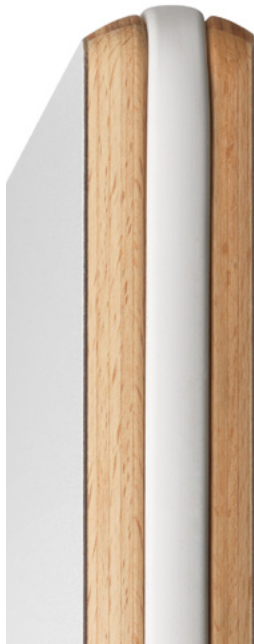

Confair folding table. 440 range. Power options.

Wilkhahn



Flexible technistation Compact Add with features as required



Integrated technistation Compact



Cable outlets



Single table portal Executive



Single table portal Executive



For wireless charging



Integrated technistation Compact Duo with features as required

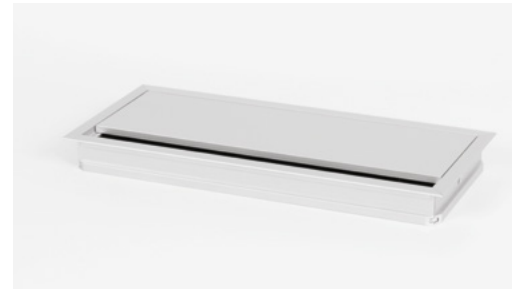

Single table portal Basic



Single table portal Basic



Integrated techni-station Rotate



Integrated techni-station Rotate



Socket strips

Please refer to the price list if you would like to integrate the techni-stations based on table models.

Confair folding table. 440 range. Power Bar.

Wilkhahn



Even when tables are linked, the Power Bar makes supplying power to the Confair folding tables very easy. Instead of giving each table its own electricity supply, depending on the sockets and devices connected, several tables can be connected directly with one another at once. This cuts the number of connections required, the potential for tripping up, shortens set-up times in seminar and conference rooms and also means that spaces can also be used as temporary offices. The lockable and strain-relieved connecting system stems from stage equipment and rules out any risk of using it incorrectly, making it very safe. As a result, tables can be detached or added at any time. The table ranges remain flexible enough to be configured by users themselves without calling on any skilled personnel to do the job.

One Power Bar each is fitted via a cable channel underneath each half of the Confair folding table. Even with Power Bars and cable channels, the tables can be folded up and stowed away compactly until they are required.

Confair folding table. 440 range. Power Bar.

Wilkhahn



The supply lead is pushed in...



... and simply locked in place.



The next table can be connected via an extension lead to the other side of the Power Bar.



Depending on the cable length, the tables can also be placed at a distance.



A range of high-quality single table portals provides access to the modules and cable channel. A power connection and up to four spare slots to configure as desired tick all the boxes (as a standard, ports available in versions to comply with the German, French and British standard).

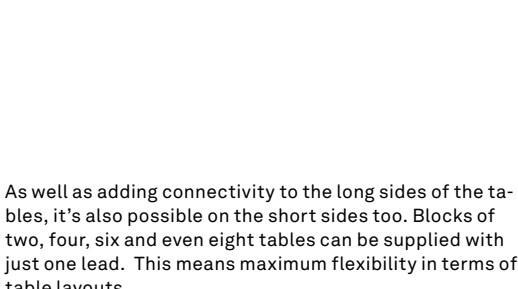

As well as adding connectivity to the long sides of the tables, it's also possible on the short sides too. Blocks of two, four, six and even eight tables can be supplied with just one lead. This means maximum flexibility in terms of table layouts.



There's even plenty of space in the cable channel for a mains adapter and residual cable.

Confair folding table. 440 range. Power Bar.

Wilkhahn

Body range

704/00

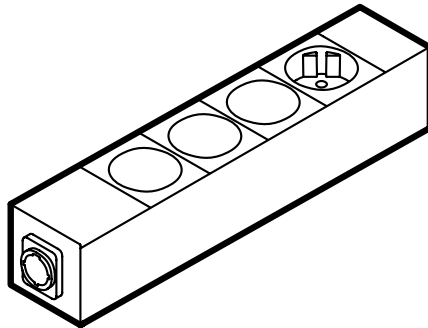

705/00

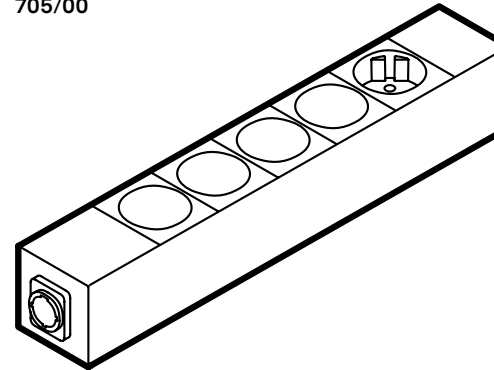

702/8

Neutrik-powerCON® supply lead
Length approx. 200 cm, 300 cm, 500 cm (78¾", 118½", 196¾")

702/8

702/9 Neutrik-powerCON® extension lead
Length approx. 80 cm, 100 cm, 150 cm, 200 cm (31½", 39¾", 59", 78¾")

Module range

Electricity

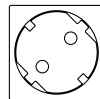

Power supply module (when ordering, please state local standard), 1 module

Charging



Dual USB-A chargers, ½ module



Dual USB-C and USB-A chargers, ½ module



USB-C power charging 60W, 1 module

Data



USB 3.0 data, Keystone module, ½ module



USB-C data (with approx. 30 cm cable), ½ module



HDMI, Keystone module, ½ module



Network RJ45, cat 6, Keystone module, ½ module

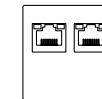

Twin network RJ45, CAT 6, Keystone module, 1 module

Blanking plates



Blanking plate, ½ module

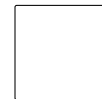

Blanking plate, 1 module

Configurable modules

Body optionally in black or white. Mod. 704/00 with three, mod. 705/00 with four configurable blank sections.

Power Bars connected with Neutrik-powerCON® cables. One power supply module is preconfigured (when ordering, please state local standard).

Power and charging connections must be configured directly after one another.

Confair folding table. 440 range. Comfort and adjustments.

Wilkhahn

Confair video

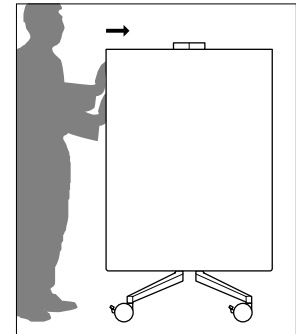
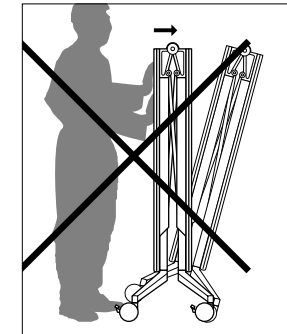
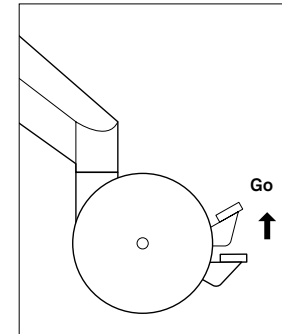
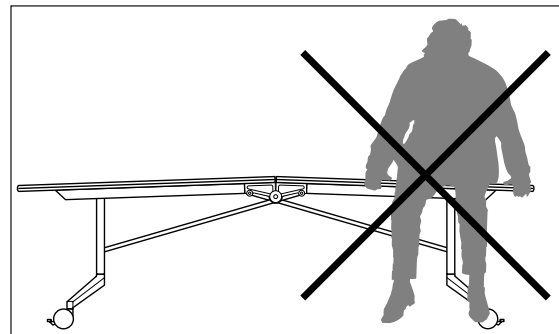
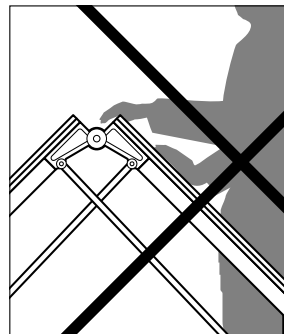
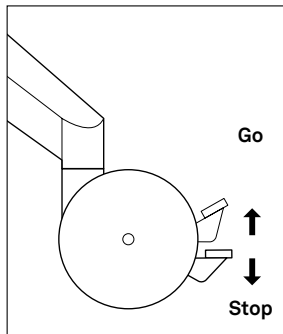
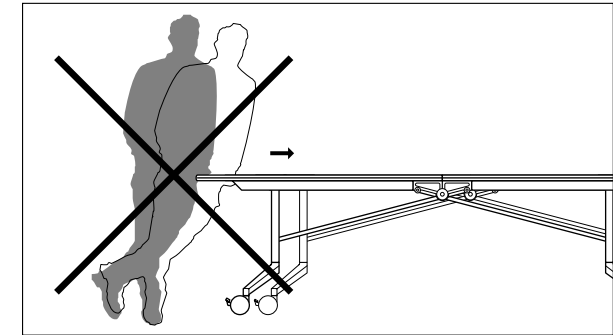
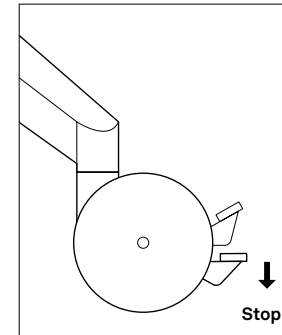
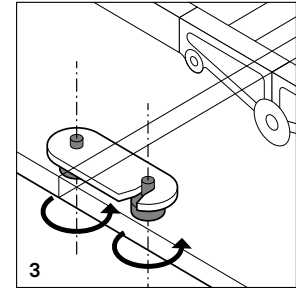
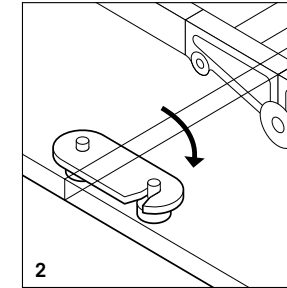
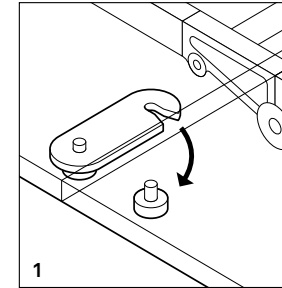
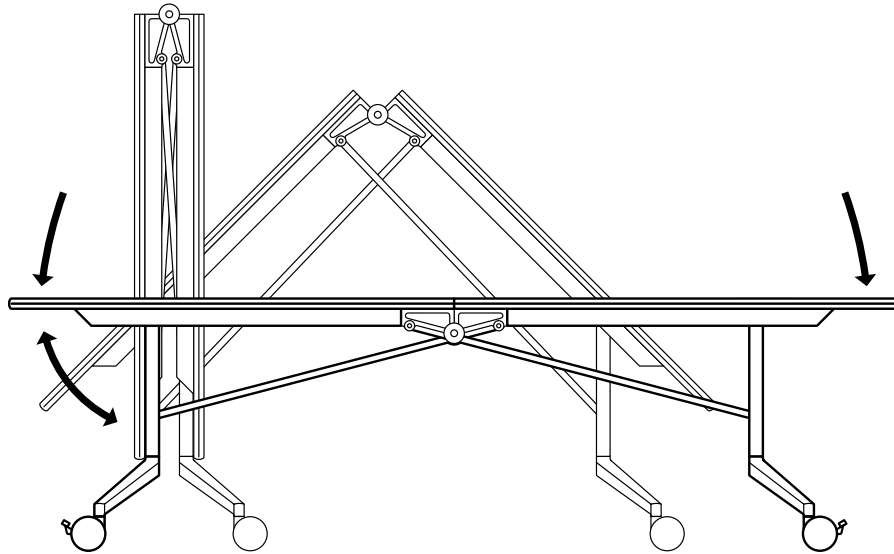

Confair folding table. 440 range. Models and dimensions.

Wilkhahn

440/00

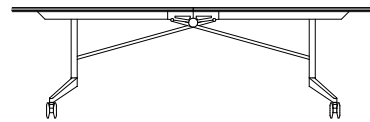
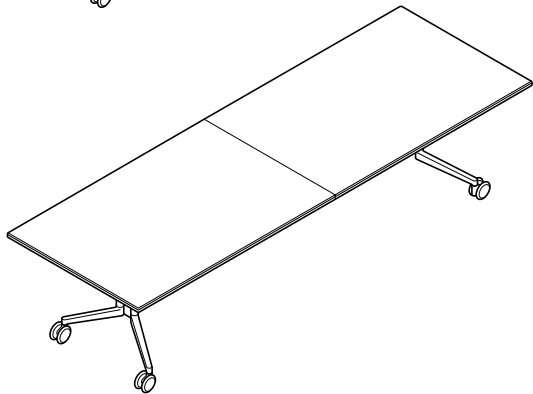
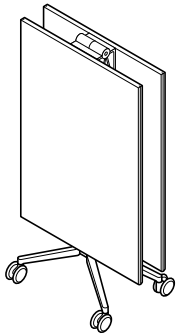

180 - 300
70 7/8" - 118 1/8"

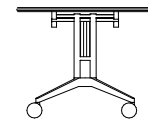

90 - 120
35 7/16" - 47 1/4"

73
28

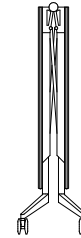

56
22 1/16"

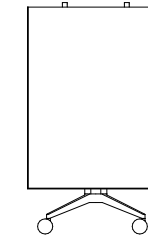

90 - 120
35 7/16" - 47 1/4"

120 - 180
47 1/4" - 71 1/8"

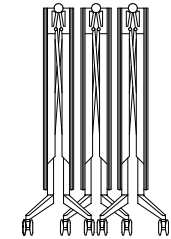

97
38 3/16"

120 - 180
47 1/4" - 71 1/8"

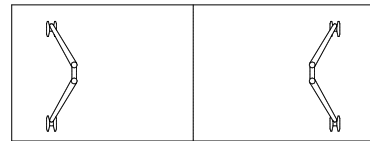

90 - 120
35 7/16" - 47 1/4"

440/00

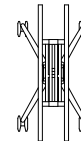

56
22 1/16"

90 - 120
35 7/16" - 47 1/4"

440/00

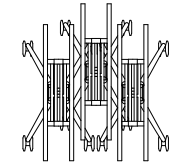

97
38 3/16"

105 - 135
41 5/16" - 53 1/8"

Depth

Width	90 (35 3/8")	100 (39 3/8")	105 (41 3/8")	110 (43 1/4")	120 (47 1/4")
180 (70 7/8")	•	•	•	•	•
200 (78 3/4")	•	•	•	•	•
210 (82 5/8")	•	•	•	•	•
220 (70 7/8")	•	•	•	•	•
240 (94 1/2")	•	•	•	•	•
260 (102 3/8")	•	•	•	•	•
280 (110 1/2")	•	•	•	•	-
300 (118 1/8")	•	•	-	-	-

Confair folding table. 440 range. Models and dimensions.

Wilkhahn

440/2

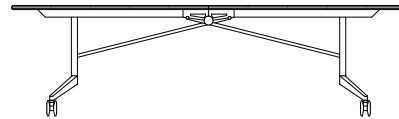
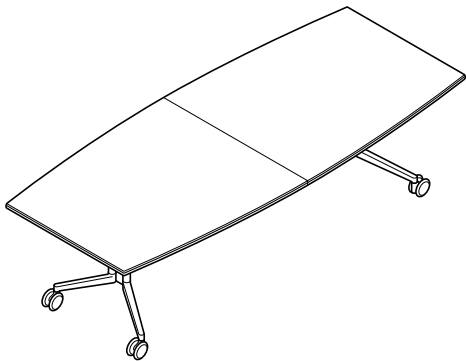
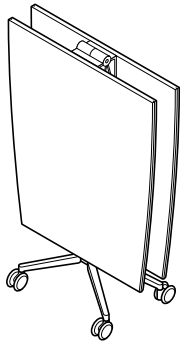

180 - 280
70 7/8" - 110 1/4"

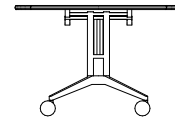

90/110 - 120
35 7/16" / 43 5/16" - 47 1/4"

73
28 3/4"



56
22 1/16"

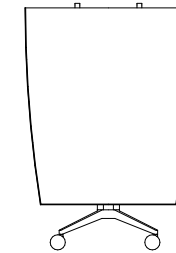

110 - 120
43 5/16" - 47 1/4"

120 - 180
47 1/4" - 70 7/8"

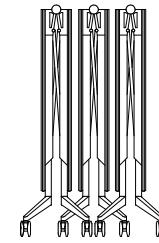

97
38 3/16"

120 - 180
47 1/4" - 70 7/8"

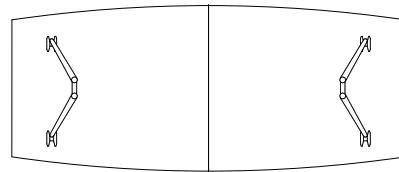

180 - 280
70 7/8" - 110 1/4"

90/110 - 120
35 7/16" / 43 5/16" - 47 1/4"

440/2

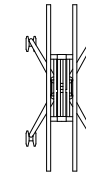

110 - 120
43 5/16" - 47 1/4"

440/2

56
22 1/16"

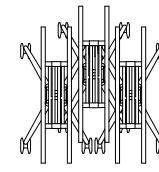

97
38 3/16"

105 - 135
41 5/16" - 53 1/8"

	Depth	
Width	90/110 (35 3/8" / 43 1/4")	90/120 (35 3/8" / 47 1/4")
180 (70 7/8")	—	•
240 (94 1/2")	—	•
260 (102 3/8")	•	•
280 (110 1/2")	—	•

Confair folding table. Programm 440. Models and dimensions/example configurations. **Wilkhahn**

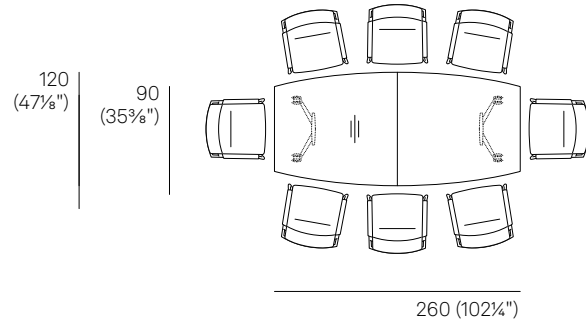

8 people,
1 x 440/2,
90/120x260 (35³/₈" / 47⁷/₈" x 102¹/₄")

665
(261¹/₄")

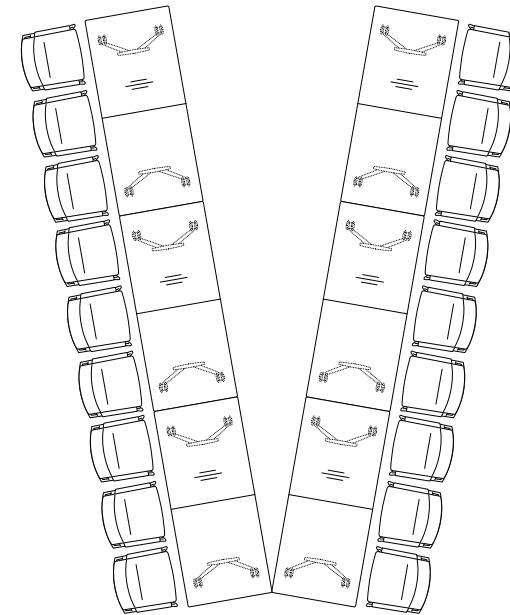

16 people,
1 x 440/00,
100x300 (39³/₈" x 118¹/₈")
4 x 440/00,
100x240 (39³/₈" x 94¹/₂")

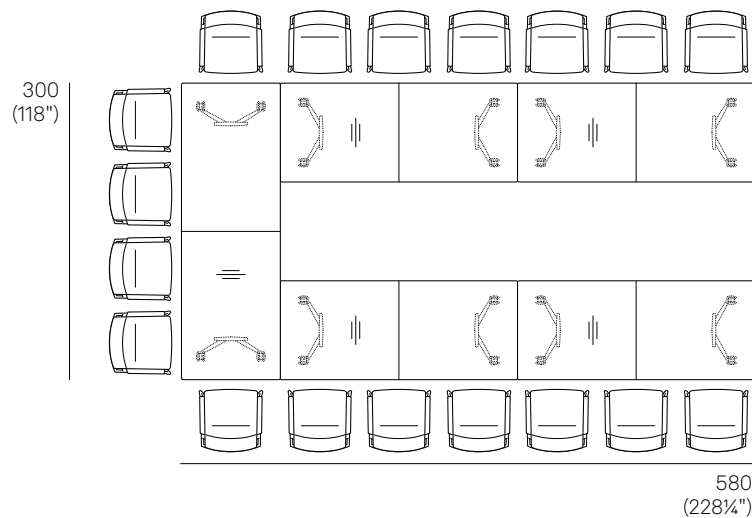

18 people,
6 x 440/00,
90x210 (35³/₈" x 82⁵/₈")

406 (159³/₄")

Confair folding table. Programm 440. Models and dimensions/example configurations.

Wilkhahn

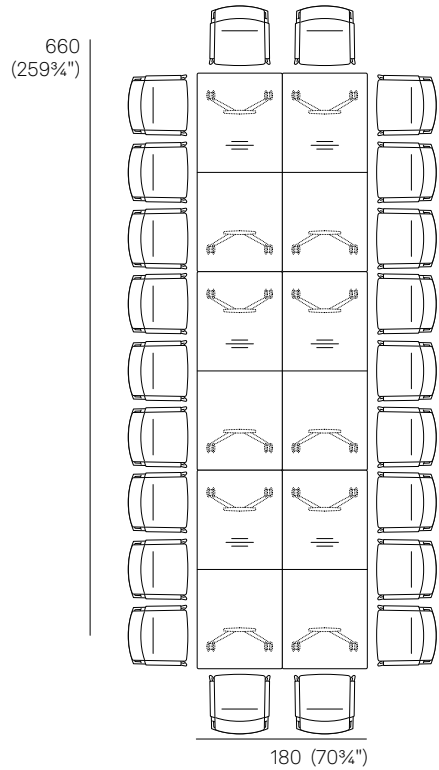

22 people,
6 x 440/00,
90x210 (35 3/8"x82 5/8")

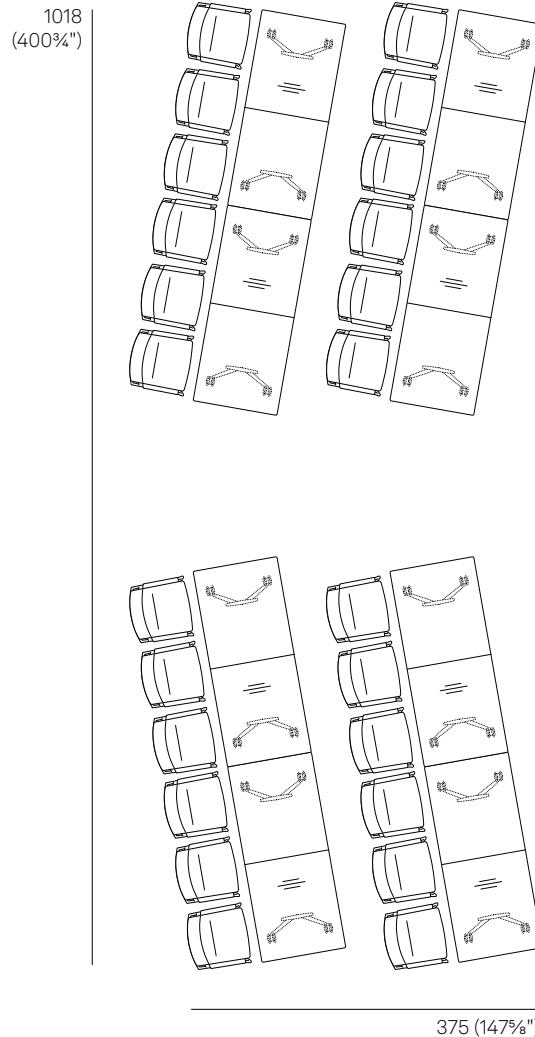

24 people,
8 x 440/00,
90x210 (35 3/8"x82 5/8")

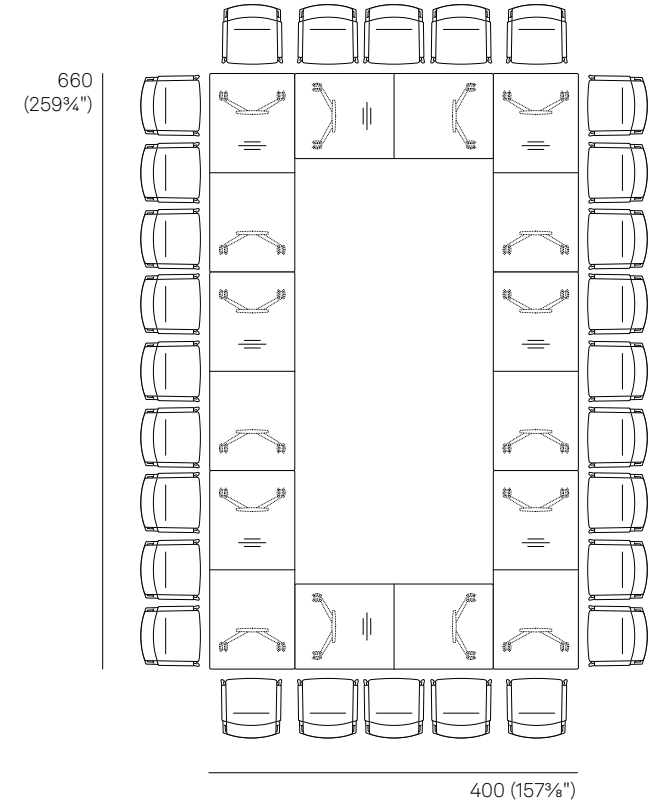

28 people,
8 x 440/00,
90x210 (35 3/8"x82 5/8")

Confair folding table. 440 range. Technical details.

Wilkhahn

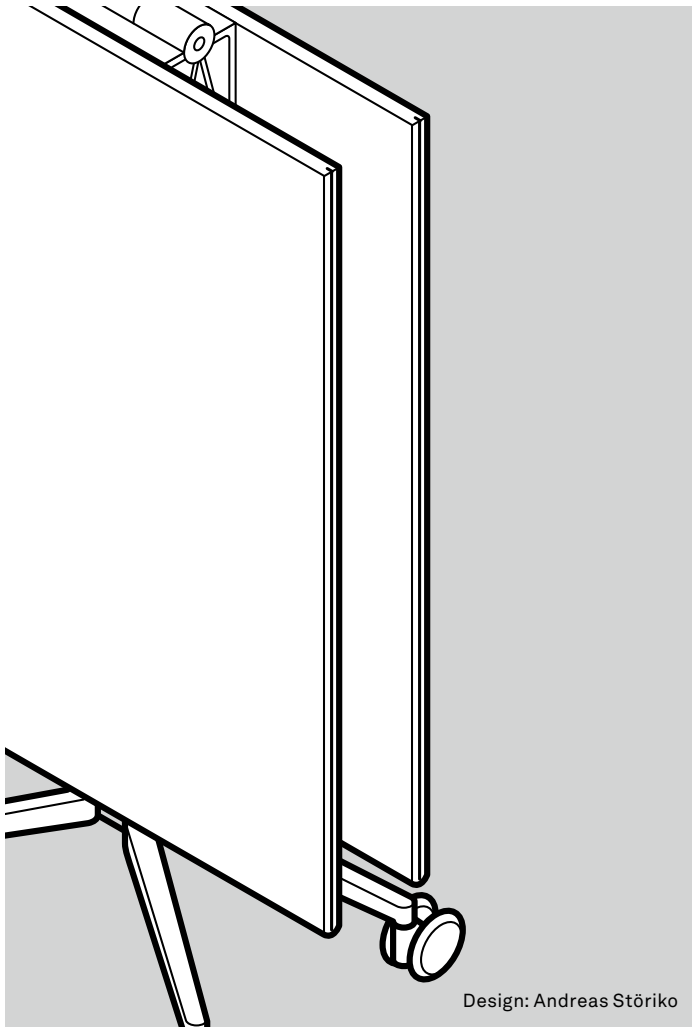

Function

Mobile, fold-up and linkable table range for dynamic use of conference and communication areas that users can set up themselves. Up to three meter long, barrel-shaped or rectangular tables can be opened out or collapsed in just one single step. The tables can also be linked to form conference systems using table-table connectors. Large casters allow the tables to be transported in buildings. A brake locks them in place. As a result, minimum cost and effort is required to manage conference spaces. Ideal for high-quality multipurpose conference interiors in high quality design and as a wild card in combination with the Logon table range for conference spaces with a variety of partition options, or with Timetable for sophisticated training and seminar spaces.

Frame

Foot section made of die-cast aluminum, with bright chrome plating, polished or coated with a silver satin finish, in black, white, black with a textured matte finish or white with a textured matte finish. Aluminum profile uprights and underframes, clear anodized or coated in the same colors as the foot sections. The bright chrome-plated foot sections are coated black. Upright optionally available with bright chrome plating. Connecting bar and T-shaped joint coated like the uprights and underframes, clear anodized uprights and underframes are coated with a silver satin finish. Connecting bar and T-shaped joint optionally bright chrome-plated. Lockable, black polyamide casters.

Core material of table top

Depending on the depth of the table top, chipboard with bullnose (double) or straight wood edging all the way round with integrated impact-resilient profile made of black elastomer or with straight plastic edging all the way round. Straight version of table top without any profile along central joining edge.

Table top group 1 – laminate

Table top thickness 26 mm

Variant 1

Laminate (single color) based on Wilkhahn's color and surface samples with wood edging, natural oiled finish or color-matched plastic edging.



Bullnose double wood edging with impact-resilient profile



Straight wood edging with impact-resilient profile

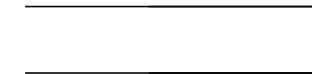

Straight plastic edging
Wood decor laminate from the Wilkhahn color and surface samples with color-matched plastic edging.

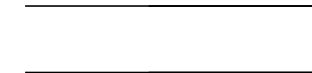

Straight plastic edging

Confair folding table. 440 range. Technical details.

Wilkhahn

Variant 2

Soft matte laminate from the Wilkhahn color and surface samples with wood edging in natural oiled finish or color-matched with the plastic edging. Antireflective, antifingerprint soft touch surface.

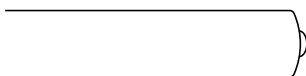

Bullnose double wood edging with impact-resilient profile



Straight wood edging with impact-resilient profile

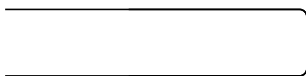

Straight plastic edging

Table top group 2 – veneer

Table top thickness 26 mm

Variant 1

Beech, oak, or ash veneer from Wilkhahn woodstain color samples with straight wood edging, color-matched as far as possible with the veneer.

Variant 2

Maple, elm or walnut veneer veneers from the Wilkhahn woodstain color samples with edging, color-matched with the veneer as far as possible.



Bullnose double wood edging with impact-resilient profile



Straight wood edging with impact-resilient profile

Veneer type

As a standard, the veneers are made by slip-match method. Surfaces sealed with clear lacquer: open-pore: Oak, walnut and elm veneer closed-pore: Maple and beech veneer. Some specific growth features possible.

Standards

The Confair folding tables comply with the ANSI/BIFMA X 5.5 standard.

Confair folding table. Environment and product.

Wilkhahn



Confair folding table. A durable classic for better use of space and made of one-type materials.

The Confair folding table is an impressive example of how to achieve financial, social and ecological improvements due to a design that's smart, functional and high quality. The focus is on people and their potential. The fact that they can easily configure their own environments cuts facility management costs and saves expenditure for building and maintaining extra spaces. Because the Confair table can be folded up, there's space for it in any elevator, so it can be used on any story. Wilkhahn's ecological design principles are all about durability and the careful choice of materials, furniture that's easy to repair and service so that the folding tables have virtually unlimited use.

- This popular table's design has had a good track record for over 25 years and is just as contemporary today as it was at the beginning. And then there's the ingeniously easy way it's folded out without requiring much muscle power and its large wheels that have no problem negotiating bumps or raised sections in the floor.
- Most of the parts of the frame, such as the die-cast aluminum or aluminum-extruded-profile foot sections, uprights and underframes, as well as the steel synchro-adjustment mechanism spring, are made of recycled materials. They are fully recyclable, exceptionally durable, lightweight to handle

and keep to dimensions. The four lockable casters are also made of unbreakable, through-dyed polyamide, designed to last and last and can be recycled.

- The table tops consist of laminboard with solid wood edging. Natural materials such as linoleum, laminate and genuine wood veneers, are used for the surfaces. Veneered table tops are protected with water-based varnish low in solvent content. The integrated polypropylene impact-resilient profile protects the edges and prevents damage.
- All parts of the frame and table tops are screwed on so that the table tops can be taken off and reconditioned, or replaced if there are signs of wear and tear.

The Confair folding table has created brand-new opportunities for designing, furnishing and using conference spaces in a material- and energy-saving way. The product's durable, versatile and its design is ecological so it helps make a big difference to a building's carbon footprint too.

Milestones of socio-ecological development at Wilkhahn

- 2019 and 2020 Presented with the Architects' Darling Award as a winner of the cradle-to-cradle challenge
- 2018 Wilkhahn receives the B.A.U.M. environmental prize and an award from the Lower Saxony Alliance for Sustainability.
- 2013 The company is connected to the district heating grid of a biogas plant nearby
- 2012 The ON office chair is presented with the Federal Ecodesign Award
- 2009 Wilkhahn signs a framework agreement with German trade union BHI (Building and Woodworkers International) on worldwide compliance with core ILO labor standards at Wilkhahn and its suppliers via in-house controls and external monitoring by German trade union IG Metall.
- 2008 A combined heat and power plant based on renewables is commissioned.
- 2001 First company in the state of Lower Saxony with EMAS 2 European environmental standard certification.
- 2000 Publishes one of the first medium-sized business reports on sustainability
- 1997 Corporate Conscience Award from the Council on Economic Priorities, New York
- 1996 German Environmental Prize from the German Environmental Foundation
- 1992 The first ecologically designed production facilities with a photovoltaic roof and launch of the first office chair range to be developed based on the ecological design concept.
- 1989 Mission statement on ecological changes at Wilkhahn: "The administrative and management board have jointly decided to take ecological concerns seriously and to place greater emphasis on them than a quick profit".

Awards



Not all the awards apply to all variants.

Confair folding table. Product responsibility.

Wilkhahn

Our antidote to the throw-away society is to provide products where form, function and materials have a purpose and are long lasting. Our product responsibility concept therefore follows well-defined guiding principles.



1. Avoid waste – “the longer and better”

is the remit to our product development team. We achieve this thanks to:

- useful innovations that make life easier and more pleasant in the long term;
- durable quality of materials, surfaces and technical solutions, which guarantees quality, even years later;
- distinctive, timeless and appealing designs with the potential to become classics;



2. Reduce – “less is more”

is more than just a design principle to us, it means:

- we cut down on the materials used in order to make handling easier and to preserve resources;
- we use energy in manufacturing efficiently, for example by drawing on district heating and heat recovery in manufacturing;
- we reduce emissions, by utilizing solar power and climate-neutral energy sources (cutting CO₂).



3. Recover – “Reuse + Recycle”

In this case, the goal is to continue to use the whole product or parts of it and recycle it at the end:

- Because the products are modular, expendable parts can be exchanged and features added or retrofitted (e. g. armrest types, covers, cushions, surfaces).
- Connecting points in the product can be dismantled for easy repair.
- Where possible, we use pure materials that are marked as such, making them ideal for recycling.



4. Fairness – responsibility all along the line

At Wilkhahn, environmental and social responsibility have an equal weighting. Health and safety, training, active participation by and fair pay for employees are integral to our corporate culture. As a result, we actively encourage our suppliers and customers worldwide to improve working conditions. Which is why Wilkhahn joined Global Compact and signed an international framework agreement with the International Labor Organization (ILO) on global recognition and fostering of employee interests.

Confair folding table. Environmental product information.

Guiding principles.

Honest product design

We strive to develop durable products, increase their utility value and reduce waste. "Less is more" or "reduce to the max" are principles that Wilkhahn constantly reinterprets for the future. Ecological design guidelines are integral components of Wilkhahn product development.

A spirit of fairness

We focus on people. This implies a collaborative management style which sees employee representatives as co-managers who help shape the company. The workforce's participation in the company's success, the development of new styles of working with semi-autonomous groups and project work, as well as an established health-management system are expressions of Wilkhahn's social approach.

Ecological responsibility

Wilkhahn supports sustainable development. The balance we seek to strike between financial, ecological, social and cultural objectives in order to maintain independence defines Wilkhahn's corporate culture. Compliance with ecological quality criteria throughout the product life cycle is one of the ways we gauge our own success.

Responsibility from the very start – Wilkhahn's environmental product information.

The environmental impact of all Wilkhahn products throughout their whole product lives, which includes production of the feedstock, manufacture, use and disposal of the products, was assessed based on a life-cycle analysis (LCA).



Wilkhahn



Materials

Socio-ecological assessment of the production of the feedstock, the procurement process, the materials used and their characteristics.



Production

Socio-ecological assessment of the production and assembly processes by environmental-management and social-audit systems.



Product use

Socio-ecological assessment of the product utility phase regarding: Design, ergonomics, durability, customer service, availability of spare parts.



End of the product life-cycle

Socio-ecological assessment of the product after the end of its useful life: Disassembly and recycling capabilities, disposal and product take-back.

Confair folding table. Environmental product information.

Wilkhahn



Materials.

International product and material standards.

During all phases of a product's development, we're demanding when it comes to the characteristics of our products, the quality of the materials and components, as well as the standard of our craftsmanship. Therefore, Wilkhahn products fulfil all relevant international office-furniture standards in terms of durability, safety and ergonomics. And what's more, many Wilkhahn products have also been awarded the GS symbol which rates them as being safe and as suitable for interiors as specified by Greenguard™. The materials Wilkhahn uses such as fabrics, leather, wood, plastics or metals are primarily made by highly specialized suppliers. Our product-development department specifies the technical and aesthetic characteristics that these materials have to fulfil. Our specifications on for example strength, color-fastness, durability and other characteristics that affect the quality of our products are clearly outlined by international material standards. Rules of thumb are as follows:

- The fabrics and leather used by Wilkhahn are low on emissions and help to provide good air quality in buildings and working environments;
- Wherever possible, Wilkhahn works with ecological upholstery fabrics, such as wool fleeces, cork and coconut fiber;
- All Wilkhahn polyurethane foam is free of CFCs and has no halogenated flame retardants. This helps protect the climate and is important for recycling capabilities at a later date. Nevertheless, Wilkhahn products can also fulfil special requirements as regards fire safety in public buildings, for example by applying flame-retardant upholstery fabrics. Additional flame-retardant materials are only added if required by our customers' stringent fire safety regulations.
- The powder-coated metal finishes of the table and chair frames are hard-wearing and made without any solvents or heavy metal.
- Chrome-plated metal finishes have no harmful chrome compounds (as specified in EN 71-3).

Wilkhahn attaches huge importance to the fact that its products and the associated materials, procedures and processes are responsible in social and ecological terms. Therefore, integrated audits help us check that our partners in the Wilkhahn supply chain comply with these aspects too. We check the quality of our products by inspecting incoming goods according to established criteria. Before processing, our materials are scrutinized and the finished results checked again by trained staff before forwarding to the next department.

Confair folding table. Environmental product information.

Wilkhahn



Production.

Integrated management system

Wilkhahn headquarters in Bad Münde (Germany) are EMAS-validated and certified to ISO 14001. Wilkhahn supports relevant certification on the part of its suppliers. Wilkhahn's main production site is certified to ISO 9001. In selecting suppliers, comprehensive and proper quality management are very important to Wilkhahn.

Water conservation, material management and sustainable energy production

Water is becoming an increasingly important resource. Wilkhahn is pulling out all the stops to minimize water consumption during production and to ensure water quality is not impaired.

By treating and recycling process water, the quantities of waste water considered hazardous have been cut by 80 percent. The Wilkhahn waste management concept includes sorting waste selectively, as well as recycling and disposing of all waste fractions resulting from the production and management departments.

All Wilkhahn production facilities ensure compliance with labor and social responsibility standards, as required by the ILO (International Labor Organization). Our partnership with suppliers is based on compliance with this agreement.

Sustainability in the supply chain.

Our environmental and social responsibility doesn't stop at the gates to our own factories.

If within its power, Wilkhahn requires and promotes fair and safe working conditions and processes that don't harm the environment. Frequent assessment and on-site visits to top suppliers create trust and sustainability in the supply chain too.

Employees as partners.

Our maxim is fairness and aspects like trust and reliability define Wilkhahn's management culture and the way it involves its own workforce. Active participation by all employees is a driving force in encouraging continual and successful improvements in the environmental sector too. Whether it's a question of avoiding hazards in the workplace, of new manufacturing technologies, or of saving materials and energy – all employees can contribute their ideas for improving Wilkhahn at any time via the company's ideas management process.

Health and safety

Wilkhahn applies a wide range of measures to ensure that workspaces in the Wilkhahn production department are safe and allow as risk-free an approach as possible. This is achieved by:

- Planning safe procedures and workspaces;
- Organizing and defining responsibilities;
- Informing people about the risks the workspace entails and taking measures to avoid these;
- Regularly inspecting working environments to maintain safety and cleanliness in all areas;
- Using the health and safety committee to frequently discuss risk potentials and systematically avoid accidents.

Confair folding table. Environmental product information.

Wilkhahn



Usage.

Aesthetics and design

Sustainable products must be practical. The timeless aesthetics of Wilkhahn products provide added value, making them options that are set to endure. Office work today requires maximum flexibility in terms of spaces, usage concepts, processes and people. New studies show that aesthetics have a direct impact on health.

Durability and guarantee

Product design to last is our antidote to the throw-away society. Therefore, Wilkhahn products focus on providing maximum utility value, durability and protecting resources. This means top quality that can be experienced, is consistent and perfect. It delivers timeless, distinctive design that is fascinating due to its simplicity, honesty and appeal to all the senses. Pioneering innovations are included that really give our customers constant added value in terms of ergonomics and handling. The fact that our products are extremely practical, easy to disassemble and components are replaceable ensures they are resource-efficient.

Air quality and emissions of harmful substances

Wilkhahn products don't emit any concentrations of gas that are harmful to the environment or health. In the US, Wilkhahn products have GREENGUARD Indoor Air Quality™ certification. GREENGUARD™ is a certification program for products low in emissions.

LEED

Wilkhahn office chairs and table ranges help companies to achieve credit points during LEED certification (U.S. Green Building Council's Leadership in Energy and Environmental Design). The LEED Green Building Rating System is a voluntary standard given to companies that offer a healthy environment, save water and energy and comply with stringent environmental criteria. More LEED information about our products is available on request.

Confair folding table. Environmental product information.

Wilkhahn



End of the product life cycle.

Product take-back and recycling

Even after the product has reached the end of its life, we still feel responsible and offer our customers extensive take-back and recycling services. We guarantee to take back all products that are no longer in use. Wilkhahn products are dismantled in the factory, all parts are selectively sorted in terms of their inherent materials and then recycled. By labelling the materials, ensuring they're non-toxic and easy to dismantle, we're already making sure today that the components in Wilkhahn products can be incorporated into local material and production cycles and be properly recycled and disposed of. As a result, energy-guzzling (and therefore ecologically unwise transportation) over long distances is avoided.

Disassembly and recycling

All Wilkhahn product components are suitable for non-destructive disassembly. In order to guarantee materials are sorted according to type, all components over 150 g in weight are labeled. No agents to protect materials, or organic halogen compounds are used that prevent recycling at a later date.

Reusable packaging for transport

Customers in over 90 countries choose Wilkhahn office furniture. For years we've only been using as much packaging to transport our products as is required to deliver them in one piece to our customers. Some 60 to 78% of Wilkhahn's cardboard packaging consists of recycled material. And Wilkhahn regularly uses blankets and other returnable packaging.

Confair folding table. Environmental product information.

Wilkhahn



Materials.

Model's material composition Confair 440/00, 1800 x 900 mm

	[kg]	[%]
Metals	35.74	62.8
Steel	4.33	7.6
Aluminum	31.41	55.2
Zinc	0.00	0.0
Plastics	2.23	3.9
Polypropylene (PP)	0.08	0.1
Polyamide (PA)	2.13	3.7
Polyurethane (PUR/TPU)	0.02	0.0
Others	18.89	33.2
Table top (composite wood, veneer)	18.76	33.0
Total weight	56.90	100.0
Recycling proportion	35.00	62.0
Recycling capability	56.77	99.8

Not recyclable: Powder varnish

Materials are subject to stringent checks. As part of an ABC analysis, the materials are checked to ensure they are environmentally friendly and not harmful to health. Prohibited chemicals are not used in the product at all. All feedstock is listed in a register of hazardous substances. This helps to minimize the use or allow the substitution of any potentially harmful materials.

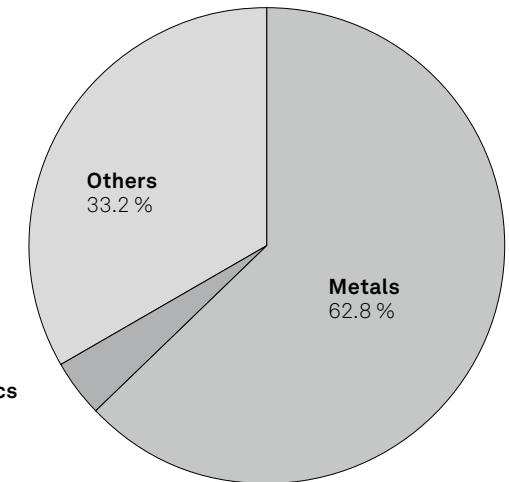

Plastics
3.9 %

Confair folding table. Environmental product information.

Wilkhahn

Certificates product/standards



ANSI/BIFMA X5.5

Company's certificates, memberships



Mitglied der DGNB Deutsche Gesellschaft für Nachhaltiges Bauen German Sustainable Building Council



Wilkhahn and sustainability

Wilkhahn



In over 100 years of its corporate history, Wilkhahn can look back on a sustainability philosophy that has grown over decades. Aspects such as durability, social fairness, environmental responsibility and cultural orientation have been evolving as corporate principles since the 1950s. Wilkhahn today is regarded internationally as a model of excellence, not only on account of its products but also because of its modern corporate philosophy. This is because the company realized early on that sustainable design should embrace environmental aspects, improve social relationships and define the cultural role of a company. This approach to the way we do business creates a bond between us and our customers throughout the world. There is surely no more rewarding task than working together for a successful future that is worth living in.

📄 [Current sustainability report with environmental statement](#)



For further information please contact us!

Wilkhahn



Wilkening + Hahne GmbH+Co.KG
Fritz-Hahne-Str. 8
31848 Bad Münde
Germany
Tel.: +49 5042 999 100
contact@wilkhahn.de
www.wilkhahn.com



Roof of one of the four pavilions,
which were designed by architect
Frei Otto, on the Wilkhahn site.

Photo: Klemens Ortmeyer